

**NOTE:**  
 LOOSE STRAW SHALL BE  
 CHINKED BETWEEN BALES TO  
 PROVIDE A TIGHT JOINT.



BAY COUNTY  
 UTILITIES  
 STANDARD  
 DETAILS

**STAKED  
 HAY BALE**

DATE : SEP 2020  
 SCALE : NTS

FIGURE : **G-1**

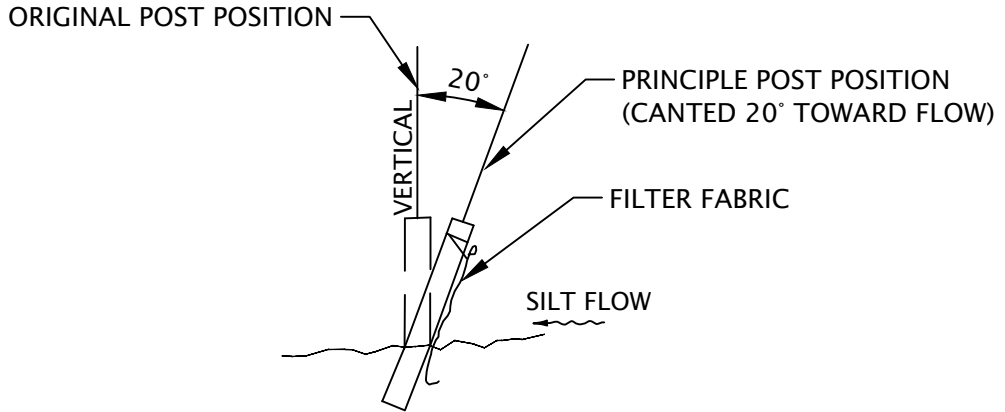

SECTION

POST OPTIONS:  
 SOFTWOOD 2½" MIN. DIA.  
 SOFTWOOD 2" X 4"  
 HARDWOOD 1½" X 1½"  
 STEEL 1.33 LBS/FT MIN.

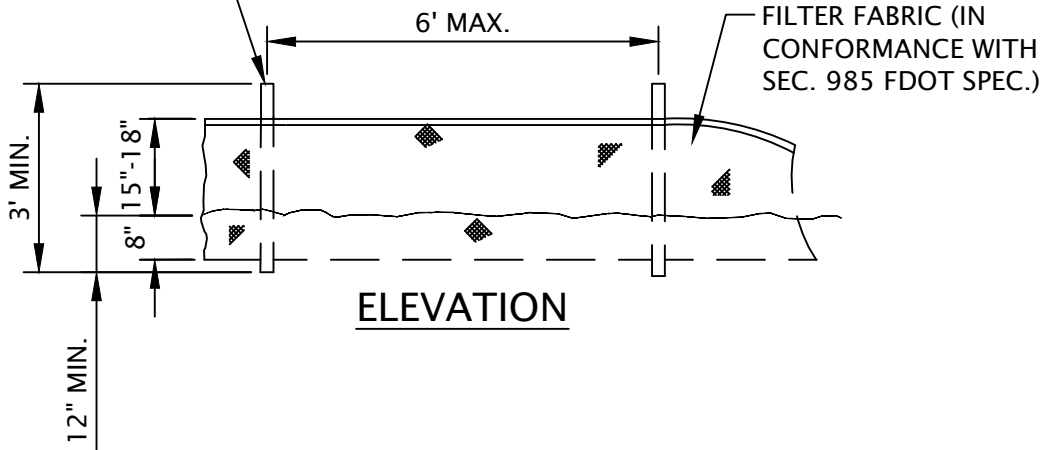

ELEVATION



BAY COUNTY  
 UTILITIES  
 STANDARD  
 DETAILS

TYPE III SILT FENCE  
 (FDOT INDEX 102)

DATE : SEP 2020  
 SCALE : NTS

FIGURE : G-2

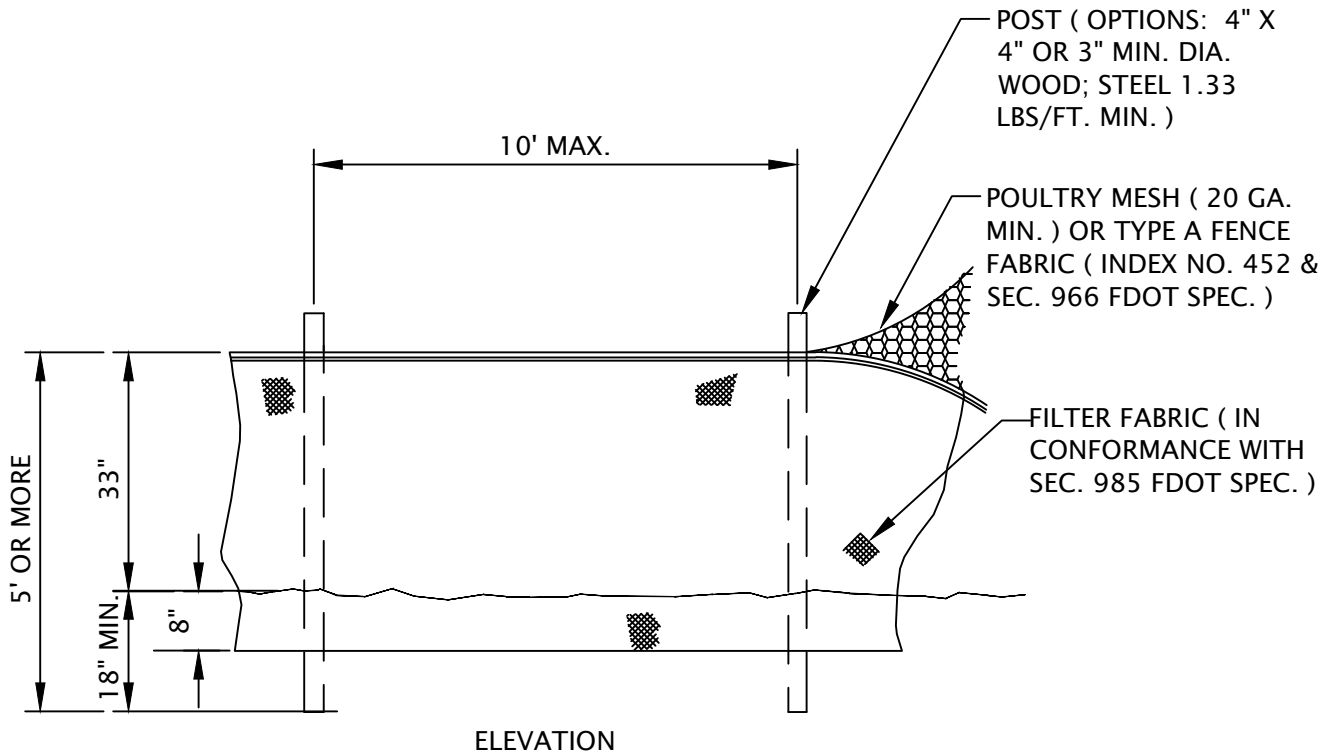
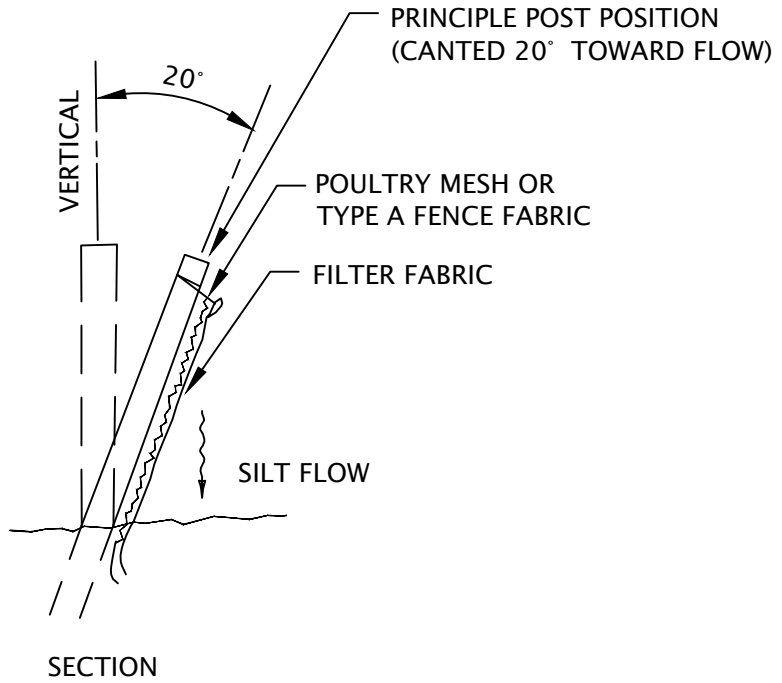

BAY COUNTY  
UTILITIES  
STANDARD  
DETAILS

**TYPE IV SILT FENCE  
(FDOT INDEX 102)**

DATE : SEP 2020  
SCALE : NTS

FIGURE : **G-3**

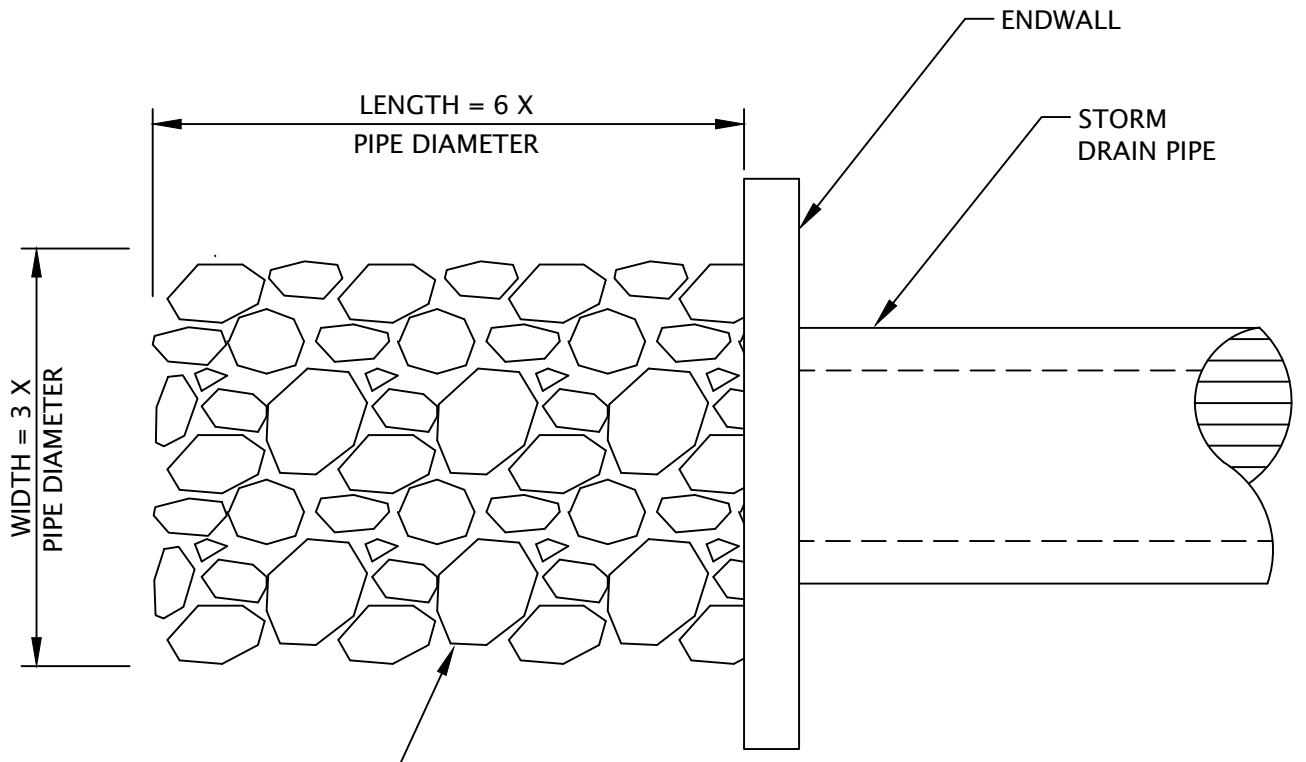

**PLAN**

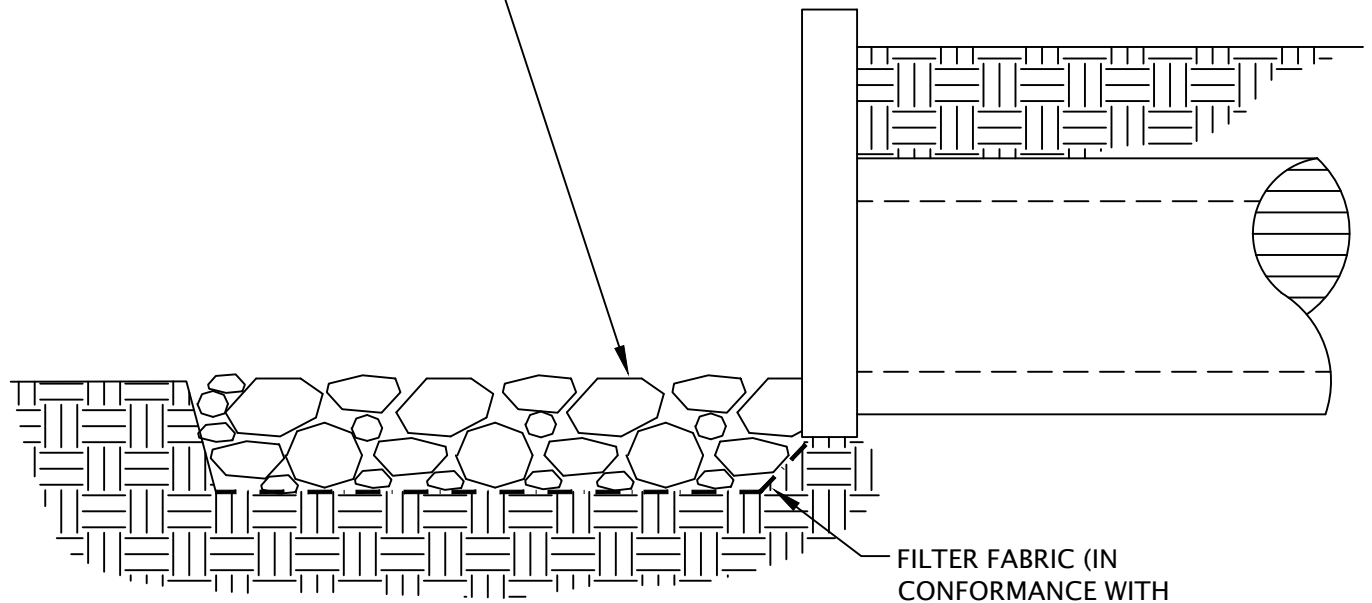

**SECTION**



BAY COUNTY  
UTILITIES  
STANDARD  
DETAILS

**STORM DRAIN OUTLET  
PROTECTION**

DATE : SEP 2020  
SCALE : NTS

FIGURE : **G-4**

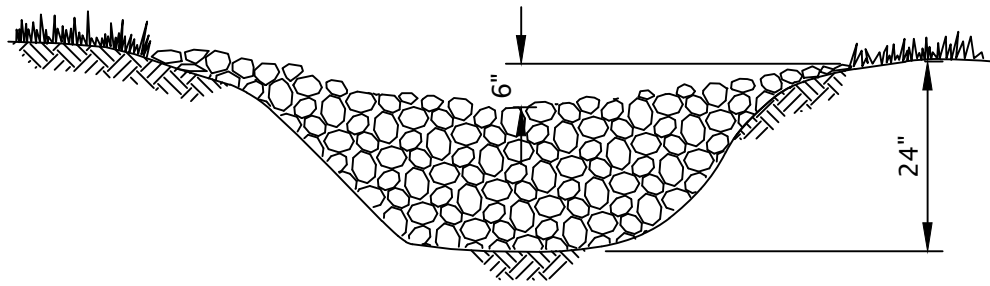

F.D.O.T. NO. 1  
COURSE  
AGGREGATE

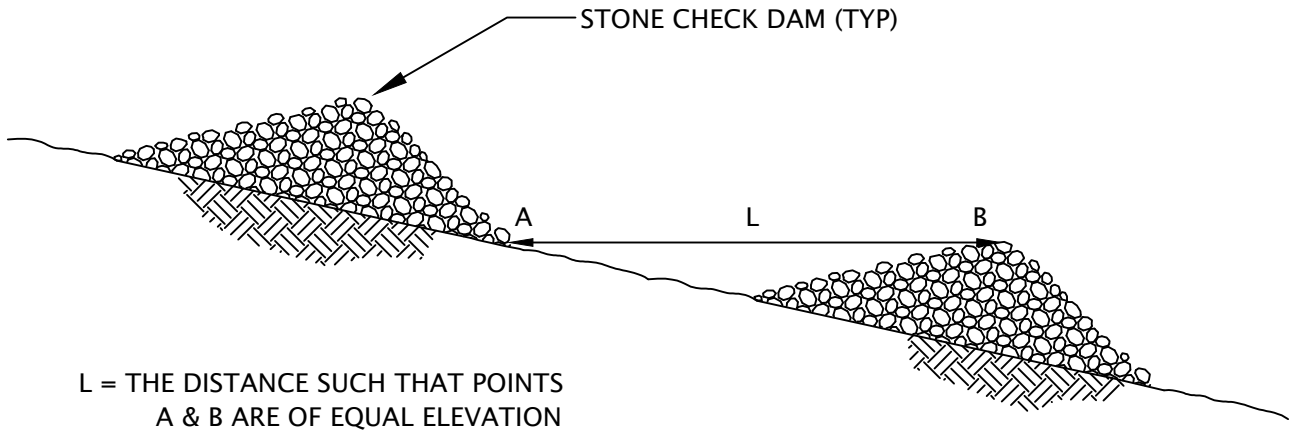
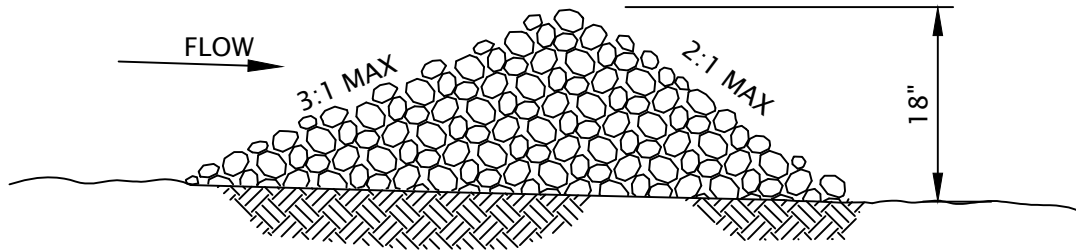

L = THE DISTANCE SUCH THAT POINTS  
A & B ARE OF EQUAL ELEVATION

NOTE TO DESIGNER: SHOW CHECK DAMS AT APPROXIMATE  
LOCATIONS ON PLAN BASED UPON LENGTH (L).



BAY COUNTY  
UTILITIES  
STANDARD  
DETAILS

### STONE CHECK DAM

DATE : SEP 2020  
SCALE : NTS

FIGURE : **G-5**

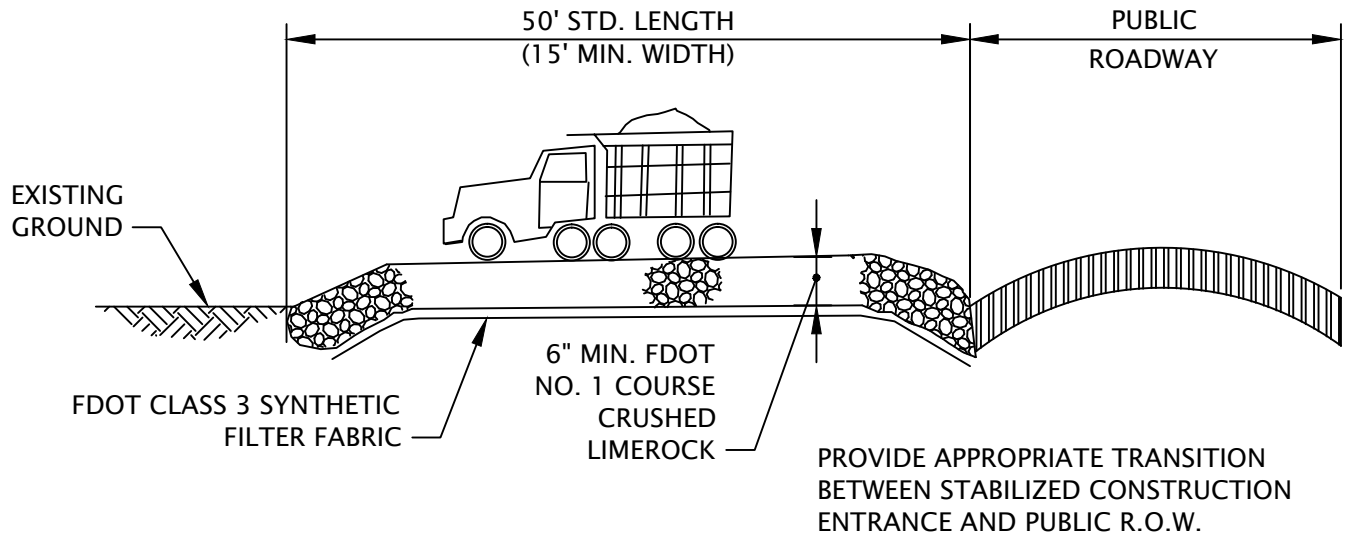

BAY COUNTY  
UTILITIES  
STANDARD  
DETAILS

## STABILIZED CONSTRUCTION ENTRANCE

DATE : SEP 2020  
SCALE : NTS

FIGURE :

G-6

SEE SPECIFICATIONS  
FOR BACKFILL AND  
COMPACTION  
REQUIREMENTS

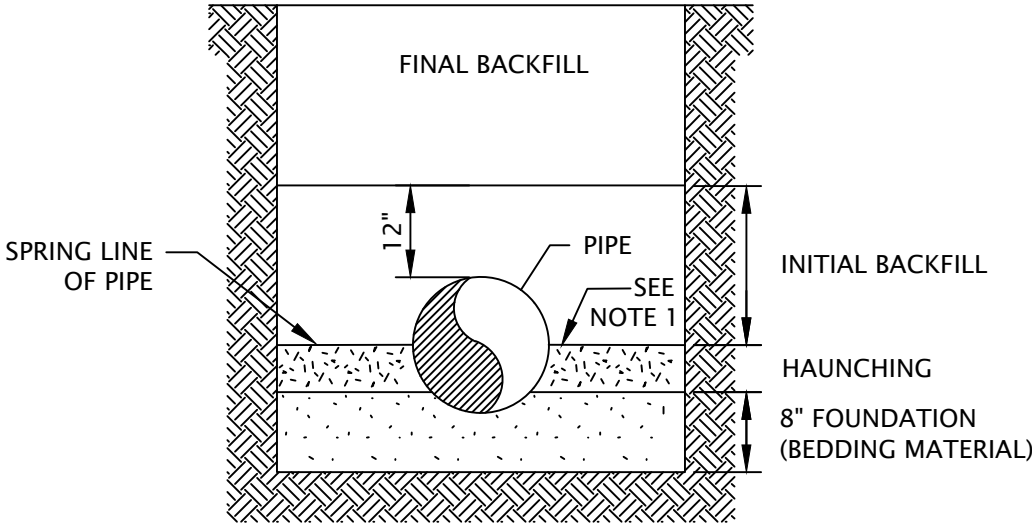

NOTES:  
1. FOR PVC AND HDPE HAUNCHING/BEDDING MATERIAL  
SHALL EXTEND TO 6-INCHES ABOVE THE TOP OF PIPE



BAY COUNTY  
UTILITIES  
STANDARD  
DETAILS

### TRENCH TERMINOLOGY

DATE : SEP 2020  
SCALE : NTS

FIGURE : **G-7**

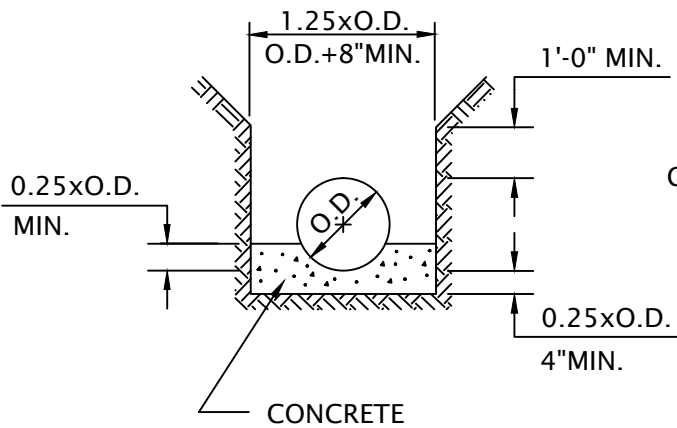

CONCRETE CRADLE

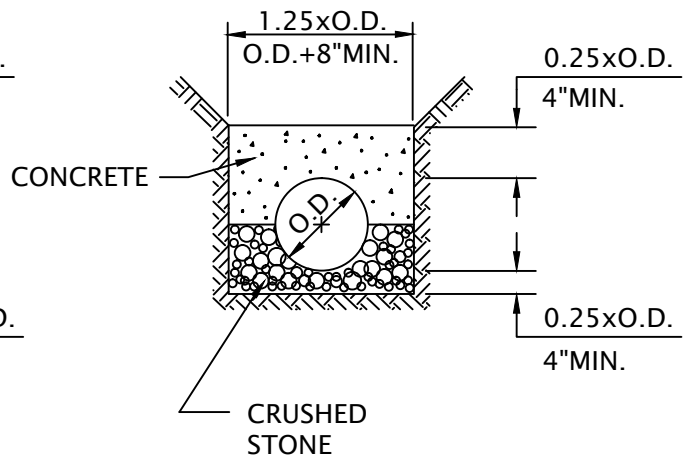

CONCRETE ARCH

CLASS "A"

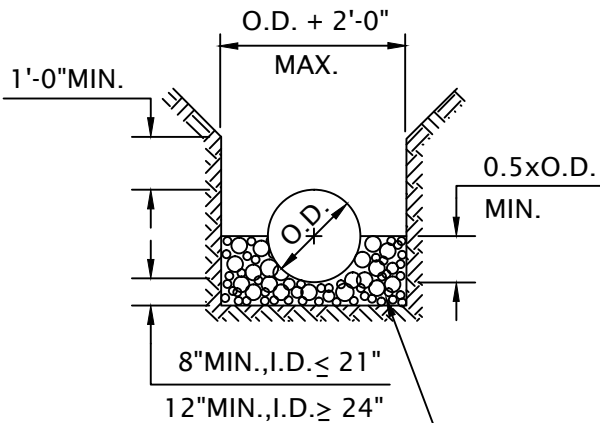

CLASS "B"

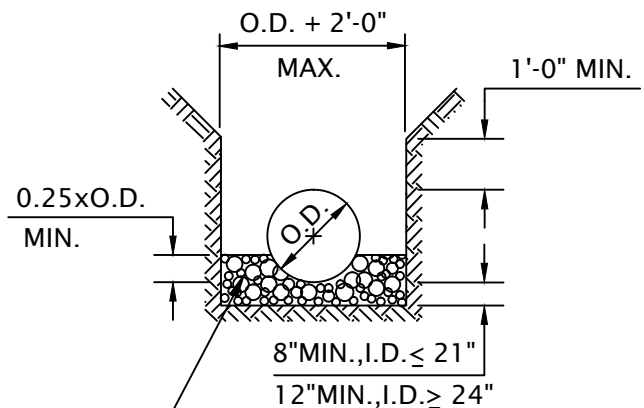

CLASS "C"

BEDDING/  
HAUNCHING MATERIAL

NOTES:

1. FOR PVC AND HDPE HAUNCHING/BEDDING MATERIAL SHALL EXTEND TO 6-INCHES ABOVE THE TOP OF PIPE



BAY COUNTY  
UTILITIES  
STANDARD  
DETAILS

PIPE BEDDING  
AND HAUNCHING

DATE : SEP 2020

SCALE : NTS

FIGURE :

G-8



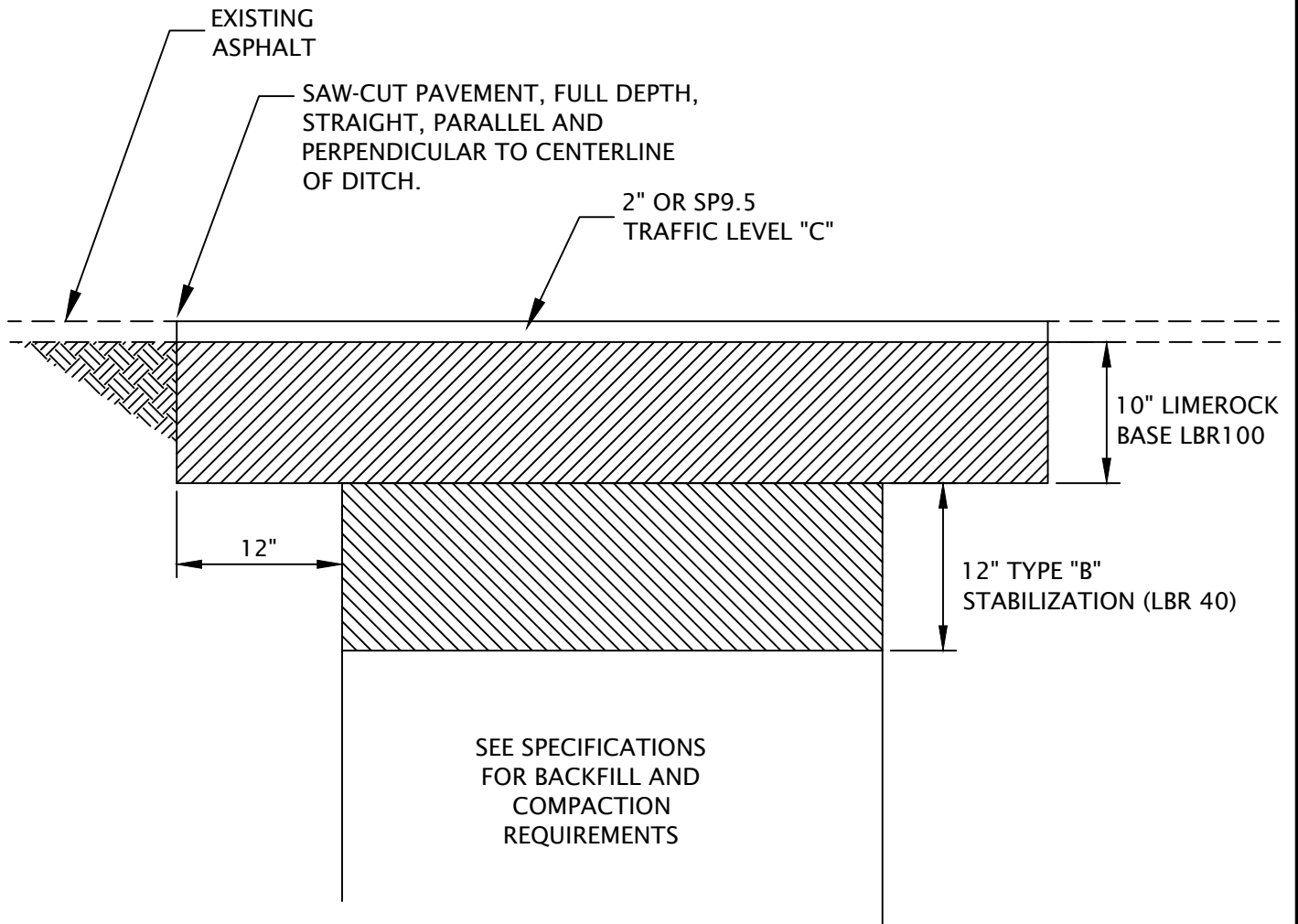

NOTE:  
 DETAIL FOR FOR DRIVEWAYS, PARKING AREAS, AND  
 LOW DENSITY RESIDENTIAL. CONTACT BAY COUNTY  
 ENGINEERING DEPARTMENT TO DETERMINE  
 REQUIREMENTS FOR REPLACING PAVEMENT ON  
 COUNTY ROADS.



BAY COUNTY  
 UTILITIES  
 STANDARD  
 DETAILS

## ASPHALT PAVEMENT REPLACEMENT

DATE : SEP 2020

SCALE : NTS

FIGURE :

G-9

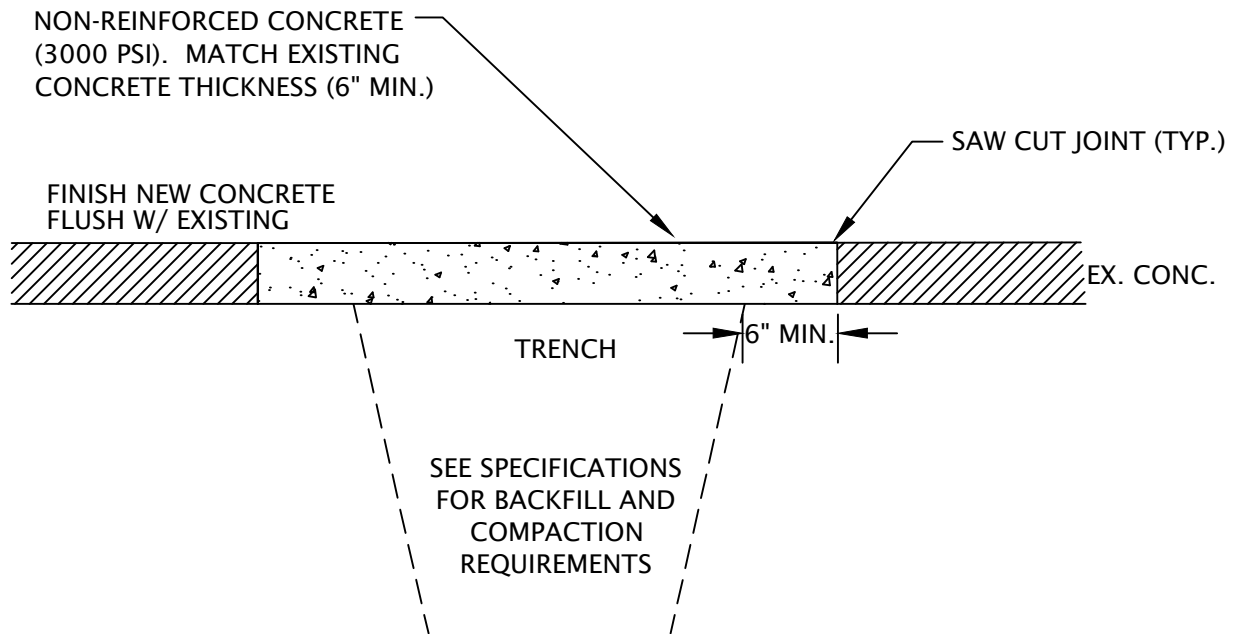

BAY COUNTY  
UTILITIES  
STANDARD  
DETAILS

## CONCRETE PAVEMENT REPLACEMENT

DATE : SEP 2020  
SCALE : NTS

FIGURE : **G-10**

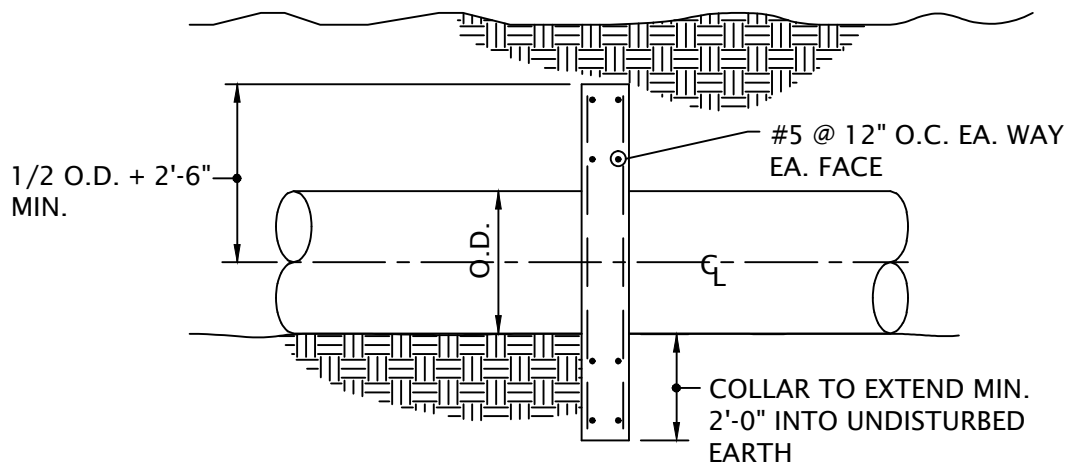
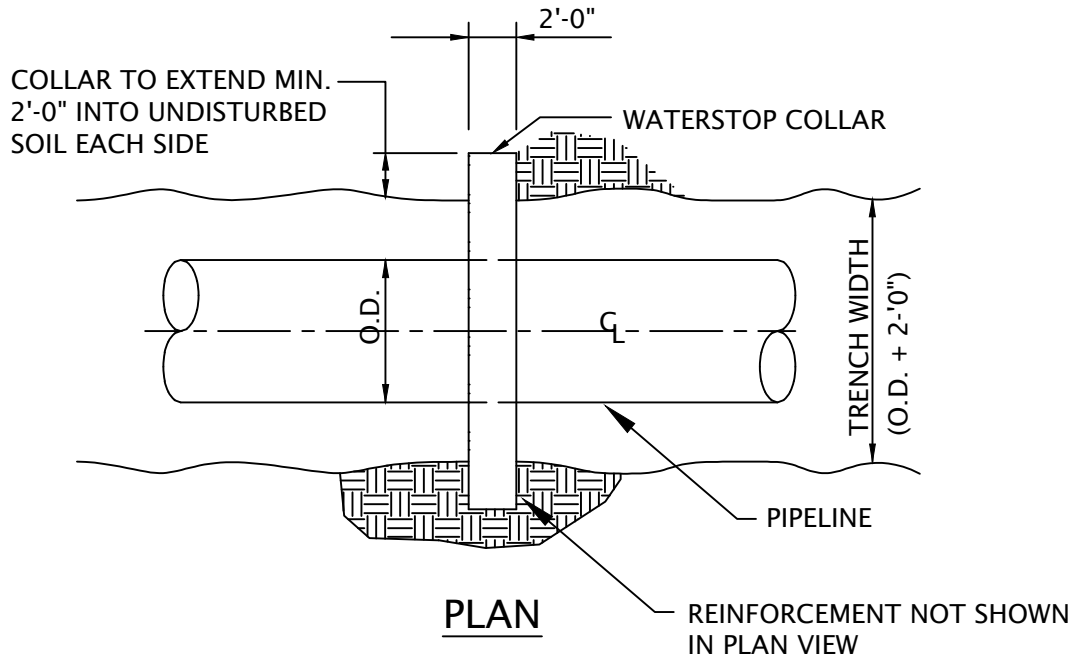

BAY COUNTY  
UTILITIES  
STANDARD  
DETAILS

**WATERSTOP COLLAR**

DATE : SEP 2020

SCALE : NTS

FIGURE : **G-11**



**BAY COUNTY  
UTILITIES  
STANDARD  
DETAILS**

# CHAIN LINK FENCE

DATE : SEP 2020  
SCALE : NTS

FIGURE : **G-12**

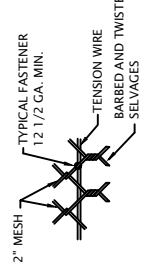
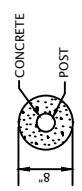
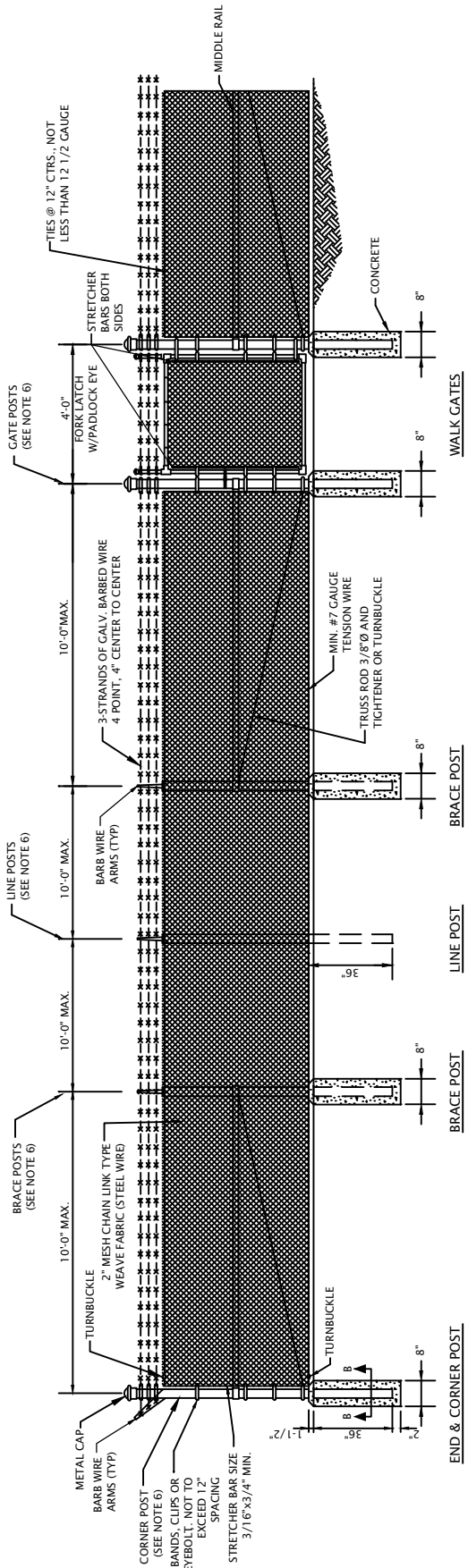

**GENERAL NOTES:**

1. ALL DIMENSION ARE TYPICAL AND MAY BE VARIED AT THE RECOMMENDATION OF THE MANUFACTURER AT INSTALLATION.
2. HOG RINGS SHALL BE GALVANIZED OR ALUMINIUM ALLOY.
3. THE TENSION WIRE SHALL BE EITHER NO. 7 GAUGE STEEL WIRE GALVANIZED AT THE RATE OF 0.7 OZ. PER SQ. FT. MIN. OR ALUMINIUM WIRE OF ALLOY ALCLAD 5056-H38 OR EQUAL WITH A WIRE DIAMETER OF 0.1875 IN. OR LARGER.
4. TENSION WIRE SHALL BE TIGHTENED TO SINGING TAUTNESS.
5. ALL TUBULAR POSTS TO HAVE A METAL CAP.
6. CORNER, LINE, BRACE, GATE POST, ETC., SHALL BE OF A SIZE SHOWN IN SPECIFICATIONS FOR A 6'-8" HIGH FENCE.
7. FENCE FABRIC SHALL BE WOVEN IN 2-INCH MESH FROM NO. 9 GAGE STEEL GREEN VINYL COATED WIRE CONFORMING TO THE STANDARD SPECIFICATION FOR ZINC-COATED STEEL GREEN VINYL COATED CHAIN-LINK FENCE FABRIC" (ASTM A392) GREEN SLATS SHALL BE WOVEN INTO THE FENCE FABRIC AFTER ERECTION.

WRAP NO. 9 GAUGE WIRE 1 1/2 LOOPS UNDER TENSION AROUND ALL POSTS AT BOTTOM ONLY, EXCEPT CORNER AND INTERMEDIATE BRACE BAYS WHICH WILL BE TIED AT THE TOP AND BOTTOM.

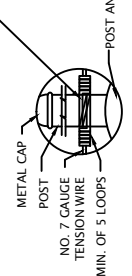

**NOTES:**

1. THE CONTRACTOR SHALL PROVIDE A SUITABLE METHOD TO VISUALLY ASSURE OBTAINING TWO (2) INCHES CLEARANCE BETWEEN POST AND BOTTOM OF CONCRETE AS SHOWN IN THE DETAIL DRAWING.
2. STRETCHER BARS FOR GATES ARE REQUIRED ON BOTH SIDES OF EACH GATE. STRETCHER BARS (SIZE 3/16"x3/4") MINIMUM ANCHOR WITH BANDS NOT EXCEEDING 12" SPACING OR OTHER APPROVED ANCHOR.

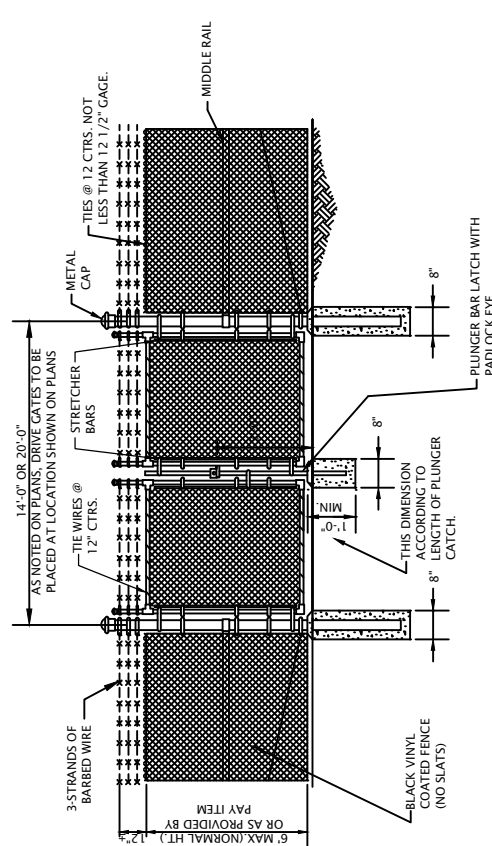

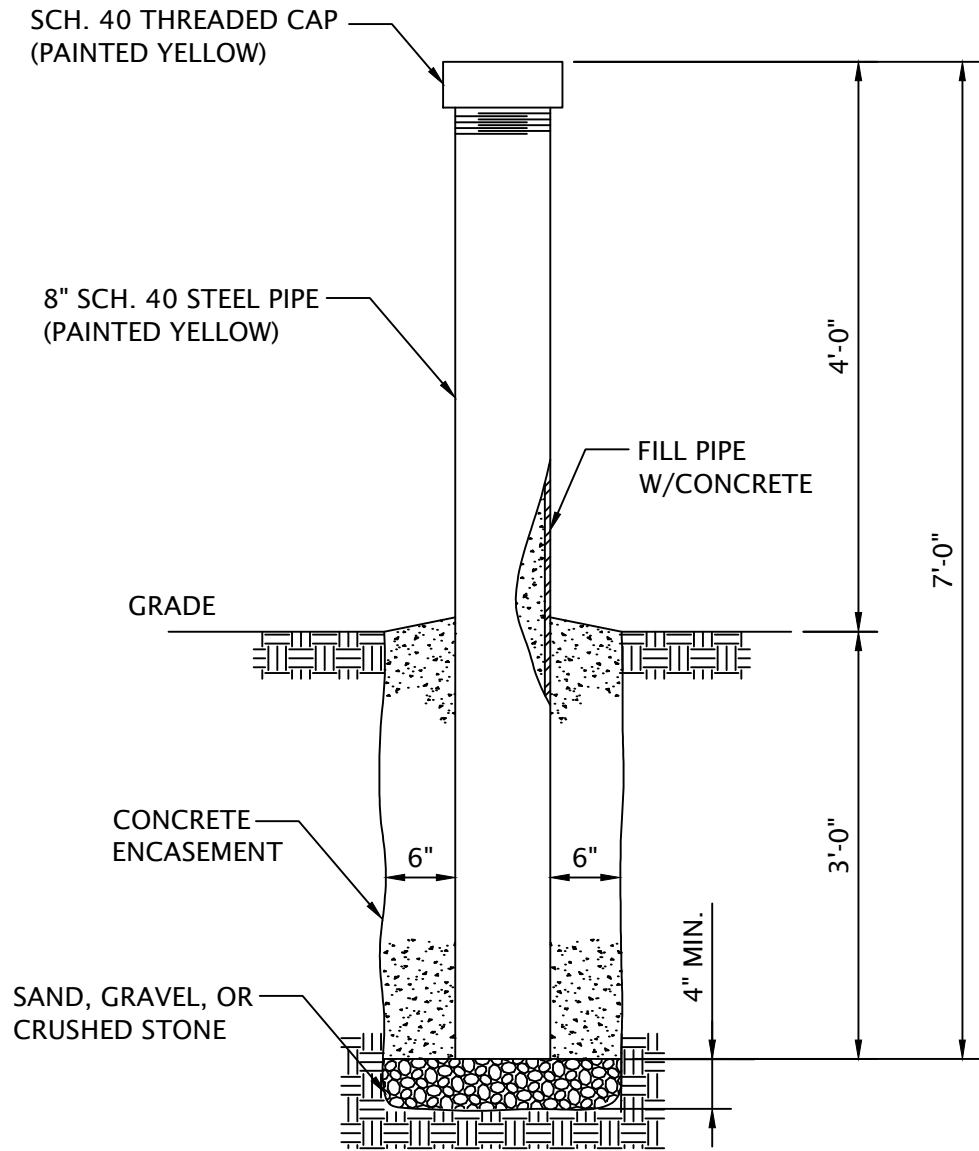

BAY COUNTY  
UTILITIES  
STANDARD  
DETAILS

**BOLLARD**

DATE : SEP 2020  
SCALE : NTS

FIGURE : **G-13**

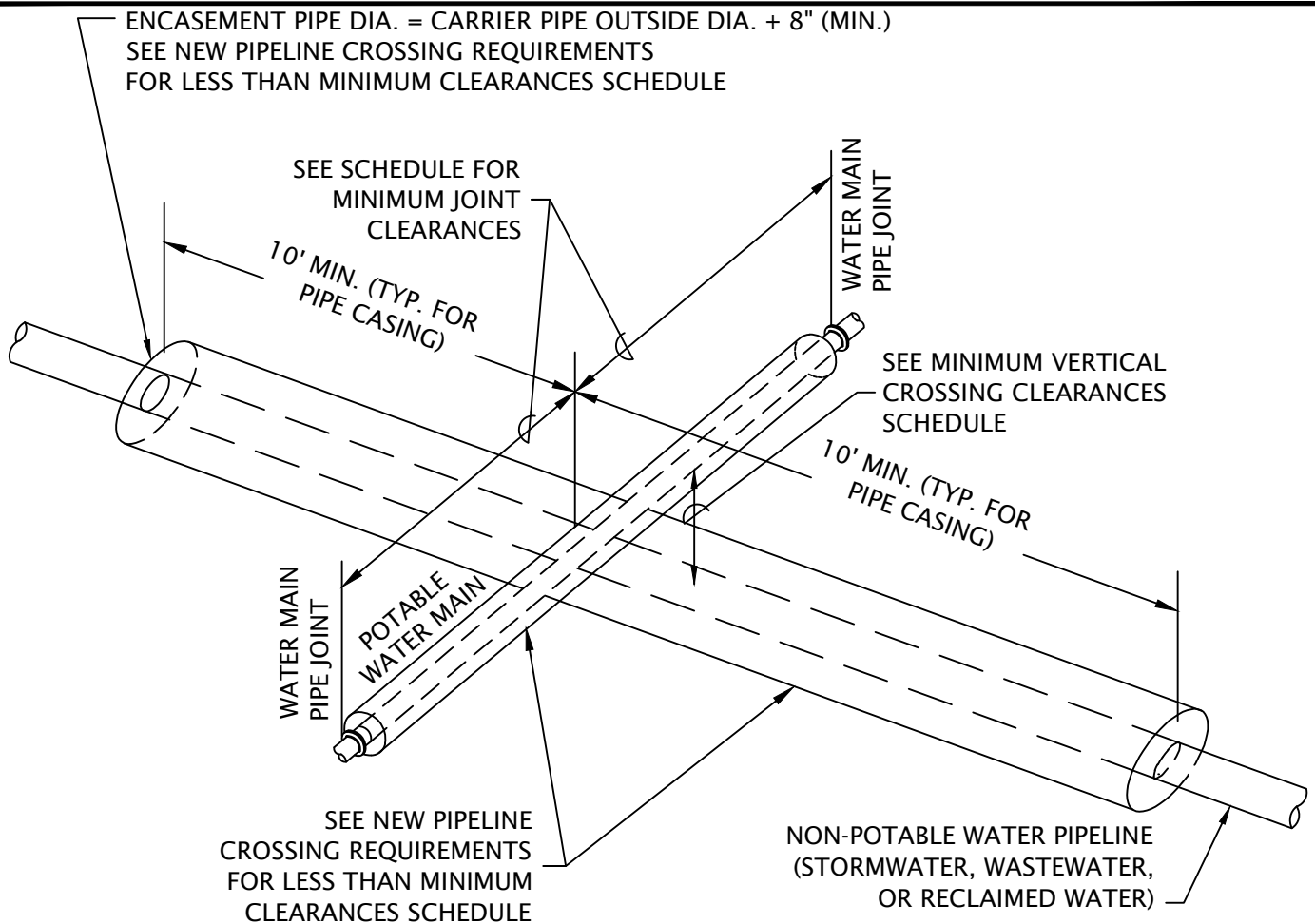

**MINIMUM VERTICAL CROSSING CLEARANCES**

1. WATER MAIN ABOVE STORMWATER (GRAVITY) OR WASTEWATER (GRAVITY & VACUUM): 6" (MIN.) 12"+ (PREFERRED)
2. WATER MAIN BELOW STORMWATER (GRAVITY) OR WASTEWATER (GRAVITY & VACUUM): 12" (MIN.)
3. WATER MAIN ABOVE OR BELOW STORMWATER, WASTEWATER & RECLAIMED WATER (PRESSURE): 12" (MIN.)

**MINIMUM WATER MAIN JOINT SPACING**

1. STORMWATER (GRAVITY & PRESSURE), WASTEWATER (VACUUM) OR RECLAIMED WATER (PRESSURE): 3' O.C.
2. WASTEWATER (GRAVITY & PRESSURE): 6' O.C.

**NEW PIPELINE CROSSING REQUIREMENTS FOR LESS THAN MINIMUM VERTICAL CROSSING CLEARANCES**

**1. POTABLE WATER MAIN:**

WATER MAIN OR WATER MAIN IN CASING PIPE OF AWWA C-150 DUCTILE IRON PIPE (DIP):

- 4"-12" - CLASS 350 OR EQUIVALENT WALL STRENGTH PIPE
- 14"-24" - CLASS 250 OR EQUIVALENT WALL STRENGTH PIPE
- 30"+ - CLASS 150 OR EQUIVALENT WALL STRENGTH PIPE

**2. WASTEWATER / RECLAIMED WATER MAIN:**

WASTEWATER / RECLAIMED WATER MAIN OR WASTEWATER / RECLAIMED WATER MAIN IN CASING PIPE OF AWWA C-150 DUCTILE IRON PIPE (DIP):

- 4"-12" - CLASS 350 OR EQUIVALENT WALL STRENGTH PIPE
- 14"-24" - CLASS 250 OR EQUIVALENT WALL STRENGTH PIPE
- 30"+ - CLASS 150 OR EQUIVALENT WALL STRENGTH PIPE

VERTICAL CROSSING SEPARATION REQUIREMENTS (SEE F.D.E.P. RULE 62-555.314(1) & (2) F.A.C.)



BAY COUNTY  
UTILITIES  
STANDARD  
DETAILS

**PIPELINE SEPARATION  
REQUIREMENT**

DATE : SEP 2020

SCALE : NTS

FIGURE :

**G-14**

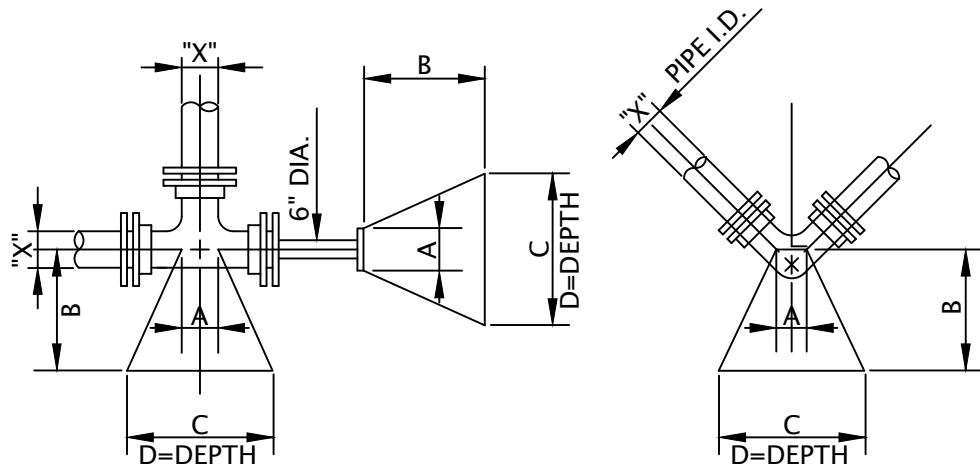

150 PSI TEST PRESSURE  
2000 PSF SOIL BEARING

	X*	A	B	C	D	
DEAD END & TEES	16"	1'-3"	3'-6"	7'-6"	4'-9"	
	12"	1'-0"	3'-0"	5'-6"	3'-6"	
	10"	1'-0"	2'-6"	4'-9"	3'-0"	
	8"	0'-10"	2'-0"	4'-0"	2'-6"	
	6"	0'-8"	1'-6"	2'-9"	1'-9"	
BENDS	90°	16"	1'-3"	5'-6"	9'-0"	5'-6"
		12"	1'-0"	4'-0"	6'-9"	4'-3"
		10"	1'-0"	3'-0"	5'-9"	3'-6"
		8"	0'-10"	2'-6"	4'-9"	3'-0"
		6"	0'-8"	1'-6"	3'-6"	2'-9"
	45°	16"	1'-3"	3'-6"	6'-9"	4'-3"
		12"	1'-0"	2'-3"	5'-3"	3'-3"
		10"	1'-0"	2'-3"	4'-6"	2'-9"
		8"	0'-10"	1'-6"	3'-6"	2'-3"
		6"	0'-8"	1'-3"	2'-6"	1'-6"
	22 1/2°	16"	1'-3"	1'-6"	4'-9"	3'-0"
		12"	1'-0"	1'-6"	3'-6"	2'-3"
		10"	1'-0"	1'-3"	3'-0"	2'-0"
		8"	0'-10"	1'-0"	2'-6"	1'-6"
		6"	0'-8"	1'-0"	1'-9"	1'-3"
11 1/4°	16"	1'-3"	1'-6"	3'-3"	2'-0"	
	12"	1'-0"	1'-6"	2'-6"	1'-6"	
	10"	1'-0"	1'-0"	2'-3"	1'-3"	
	8"	0'-10"	1'-0"	1'-9"	1'-0"	
	6"	0'-8"	1'-0"	1'-6"	0'-6"	

X\* = DIAMETER OF PIPE TO BE BLOCKED



BAY COUNTY  
UTILITIES  
STANDARD  
DETAILS

## CONCRETE THRUST BLOCK REQUIREMENTS

DATE : SEP 2020  
SCALE : NTS

FIGURE :

G-15

## REQUIRED LENGTH OF RESTRAINED JOINT PIPE FOR DR-18 PVC PIPE

MAIN PIPE SIZE	HORIZ. BENDS			TEES					REDUCERS			PLUGS & VALVES
	90°	45°	22.5°	SIZE / LENGTH					SIZE / LENGTH			
24	90	38	18	X24 / 169	X20 / 132	X16 / 90	X12 / 38	X10 / 6	X20 / 64	X16 / 117	X12 / 158	214
20	78	32	16	X20 / 141	X16 / 101	X12 / 53	X10 / 24	X8 / 1	X16 / 65	X12 / 115	X10 / 149	184
16	66	27	13	X16 / 111	X12 / 67	X10 / 41	X8 / 12		X12 / 64	X10 / 107	X8 / 111	151
12	52	22	10	X12 / 80	X10 / 56	X8 / 31	X6 / 1		X10 / 58	X8 / 62	X6 / 86	118
10	44	18	9	X10 / 63	X8 / 40	X6 / 7			X8 / 33	X6 / 61	X4 / 81	100
8	37	15	7	X8 / 49	X6 / 18	X4 / 1			X6 / 35	X4 / 60		83
6	29	12	6	X6 / 29	X4 / 1				X4 / 33			63
4	21	8	4	X4 / 12								45

**NOTES:**

1. RESTRAIN 11.25° BENDS 50% OF LENGTH FOR 22.5° BENDS.
2. ALL VALVES AND FITTINGS SHALL BE RESTRAINED TO THE CONNECTING SECTIONS OF PIPE.
3. ALL ISOLATION VALVES MUST BE PROPERLY ANCHORED OR RESTRAINED TO RESIST A 180 PSI TEST PRESSURE IN EITHER DIRECTION.
4. PIPE SIZES ARE GIVEN IN INCHES.
5. RESTRAINED PIPE LENGTHS ARE GIVEN IN FEET.
6. LENGTHS SHOWN ARE FOR A TEST PRESURE OF 180 PSI.
7. THE RESTRAINED LENGTHS SHOWN IN THESE TABLES ARE BASED ON SOIL CLASSIFICATION SP WITH AWWA TYPE 3 TRENCH CONDITIONS, 180 PSI TEST PRESSURE, 3 FEET OF COVER AND 1.5 FACTOR OF SAFETY. ACTUAL BURY CONDITIONS MUST BE DETERMINED BY THE ENGINEER OF RECORD AND THE RESTRAINED LENGTHS MODIFIED ACCORDINGLY.
8. RESTRAINED LENGTHS TO BE APPLIED TO PIPELINES PER DETAIL RESTRAINED LENGTHS FOR PIPE.



BAY COUNTY  
UTILITIES  
STANDARD  
DETAILS

### RESTRAINED JOINT REQUIREMENTS FOR PVC PIPE

DATE : SEP 2020  
SCALE : NTS

FIGURE : **G-16**



## REQUIRED LENGTH OF RESTRAINED JOINT PIPE FOR DIP (POLY-WRAPPED)

MAIN PIPE SIZE	HORIZ. BENDS			TEES						REDUCERS				PLUGS & VALVES
	90°	45°	22.5°	SIZE / LENGTH						SIZE / LENGTH				
				x36	x30	x24	x20	x16	x12	x30	x24	x20	x16	
36	142	59	28	393	318	232	165	84	1	137	247	309	359	453
30	124	51	25	333	252	189	115	23	1	137	213	276		391
24	106	44	21	270	211	143	61	10	1	98	178	241		327
20	92	38	18	225	161	85	39	8	1	98	176	227		280
16	77	32	15	177	107	65	19	6	1	98	163	169		231
12	61	25	12	127	89	50	6	1		88	96	131		181
10	52	22	10	101	64	11				51	94	125		153
8	44	18	9	78	30	1				54	92			128
6	34	14	7	46	1					50				98
4	24	10	5	19										69

## REQUIRED LENGTH OF RESTRAINED JOINT PIPE FOR DIP (NON-WRAPPED)

MAIN PIPE SIZE	HORIZ. BENDS			TEES						REDUCERS				PLUGS & VALVES
	90°	45°	22.5°	SIZE / LENGTH						SIZE / LENGTH				
				x36	x30	x24	x20	x16	x12	x30	x24	x20	x16	
36	100	42	20	163	132	96	68	35	1	57	103	128	149	188
30	88	37	18	138	104	78	48	10	1	57	88	114		162
24	75	31	15	112	87	59	25	4	1	40	74	100		135
20	65	27	13	93	67	35	16	1		41	73	94		116
16	54	22	11	73	44	27	8	6	1	41	68	70		96
12	43	18	8	53	37	21	1			37	40	54		75
10	37	15	7	42	26	5				21	39	52		63
8	30	13	6	32	12	1				22	38			53
6	24	10	5	19	1					21				41
4	17	7	3	8										29

**NOTE:**

SEE RESTRAINED LENGTHS FOR PVC PIPE DETAIL FOR NOTES 1 THROUGH 8 THAT ARE ALSO APPLICABLE TO RESTRAINED LENGTHS FOR DIP.



BAY COUNTY  
UTILITIES  
STANDARD  
DETAILS

### RESTRAINED JOINT REQUIREMENTS FOR DUCTILE IRON PIPE

DATE : SEP 2020  
SCALE : NTS

FIGURE : **G-17**

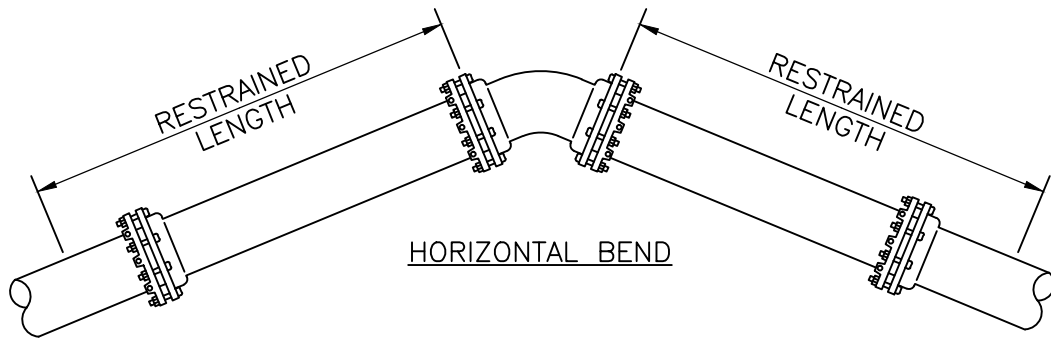

HORIZONTAL BEND

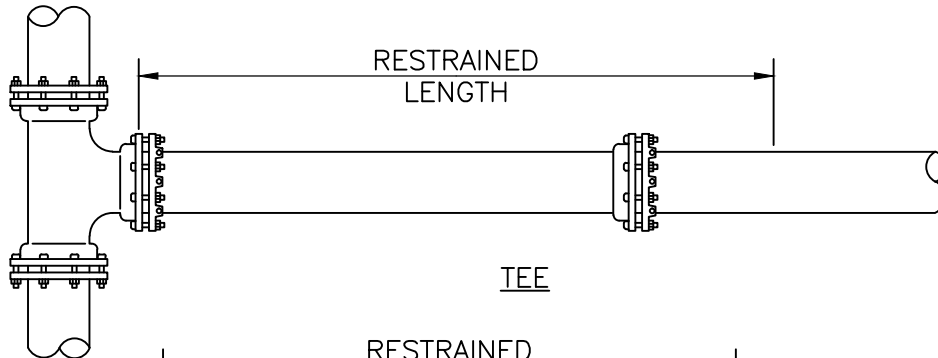

TEE

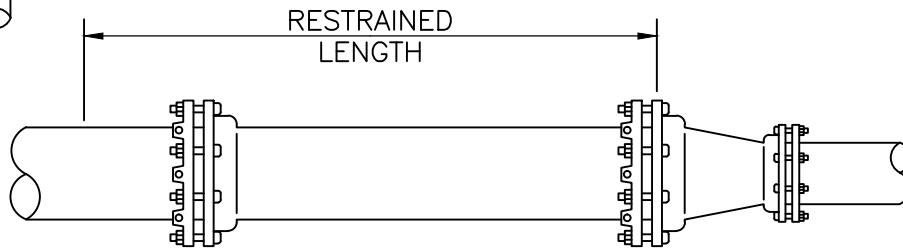

REDUCER

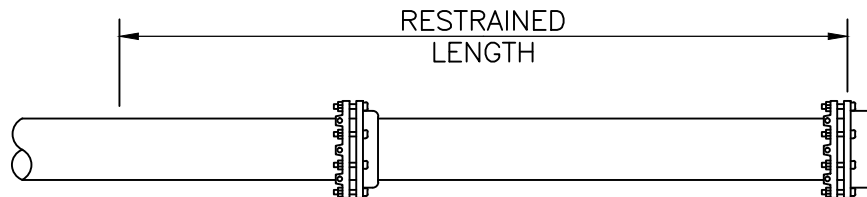

CAP OR PLUG

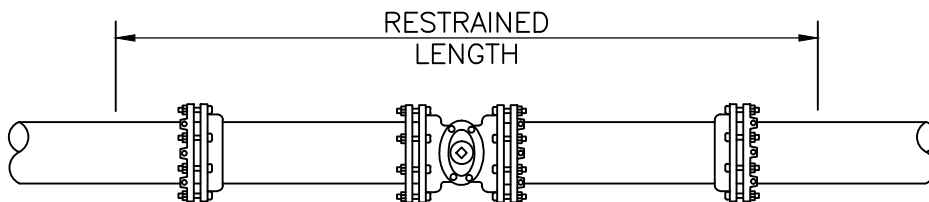

ISOLATION VALVE

RESTRAINED LENGTHS FOR PIPE



BAY COUNTY  
UTILITIES  
STANDARD  
DETAILS

**RESTRAINED JOINT  
REQUIREMENTS  
TYPICAL LENGTHS**

DATE : SEP 2020  
SCALE : NTS

FIGURE : **G-18**

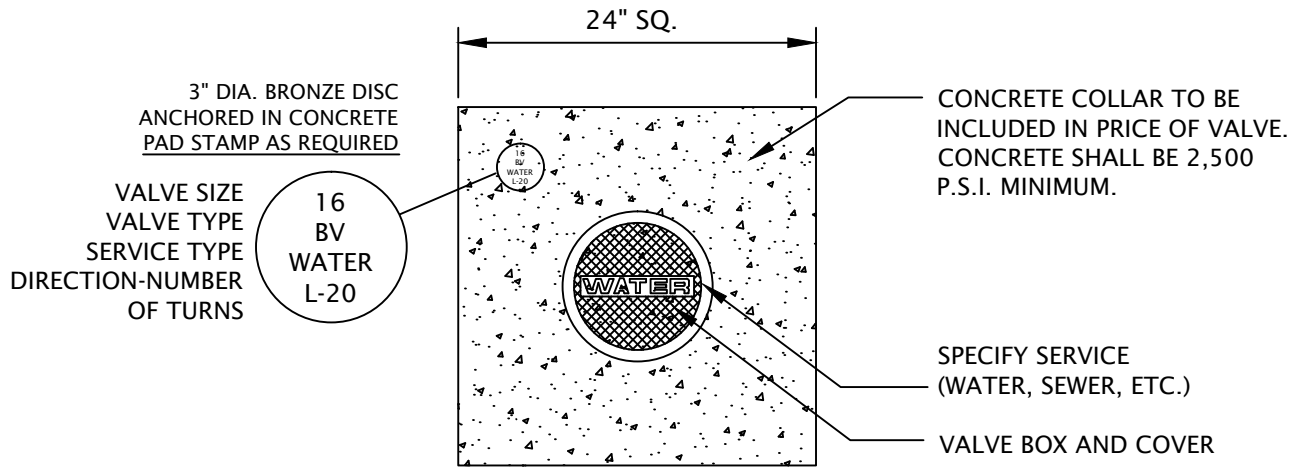

**PLAN**

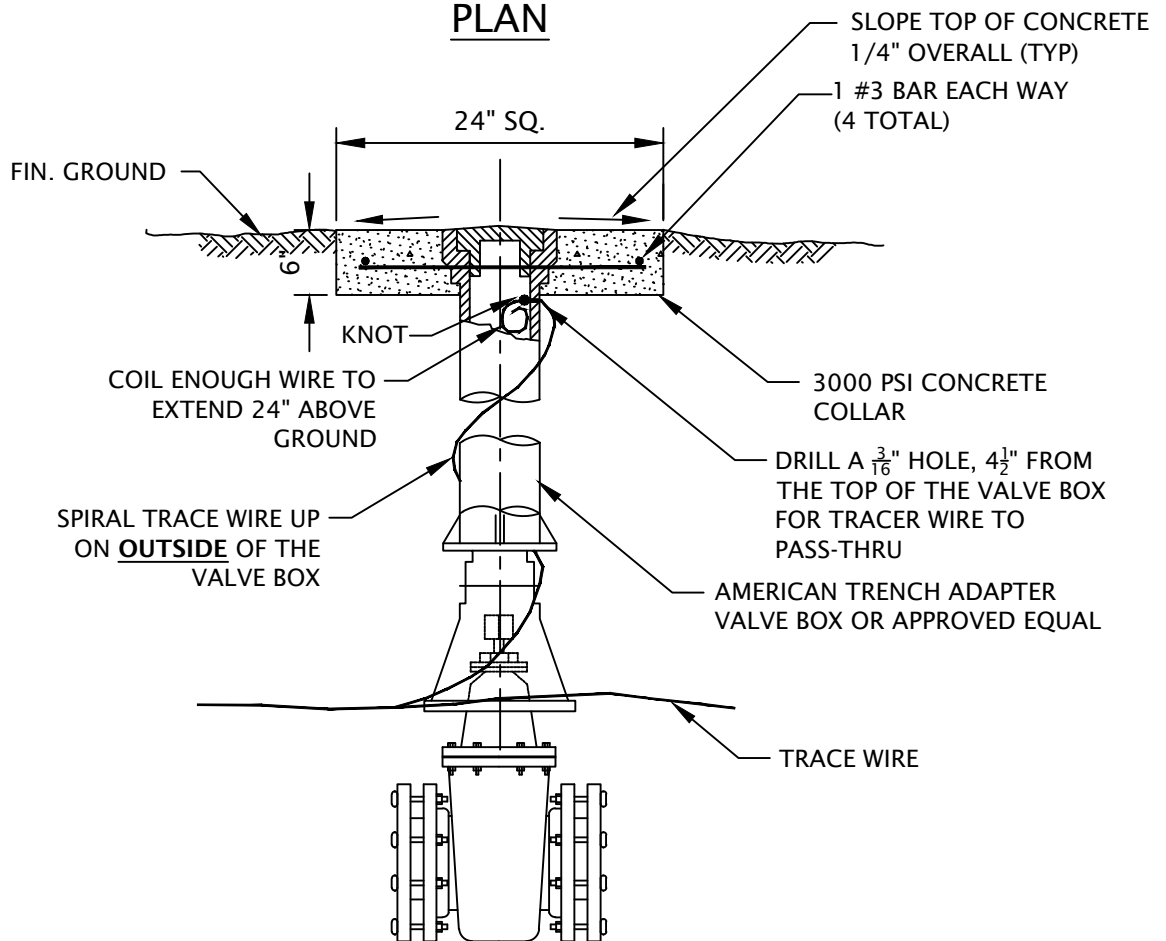

**NOTES:**

1. SEE SPECIFICATIONS FOR TECHNICAL REQUIREMENTS AND APPROVED GATE VALVES AND VALVE BOXES.
2. PVC EXTENSIONS SHALL NOT BE USED ON VALVE BOX INSTALLATION.
3. THE ACTUATING NUT FOR DEEPER VALVES SHALL BE EXTENDED TO COME UP TO 2 FOOT DEPTH BELOW FINISHED GRADE.

**SECTION**



BAY COUNTY  
UTILITIES  
STANDARD  
DETAILS

**VALVE AND  
VALVE BOX COLLAR**

DATE : SEP 2020

SCALE : NTS

FIGURE : **G-19**

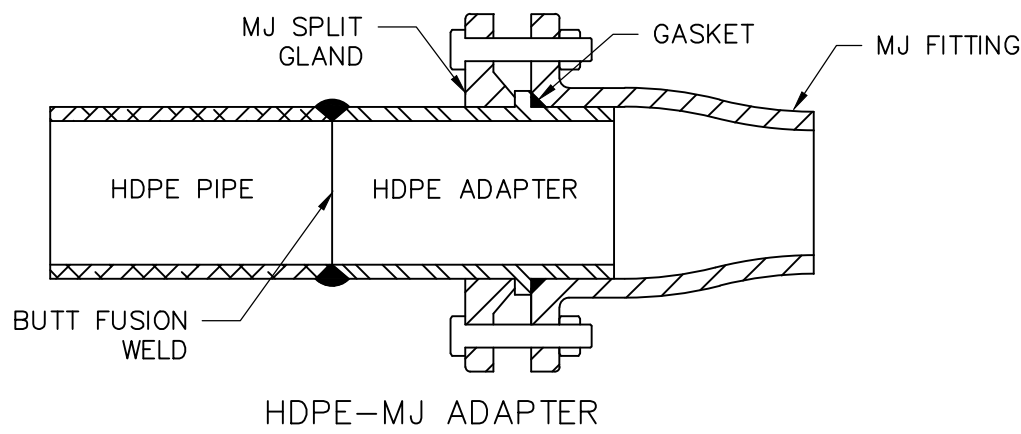
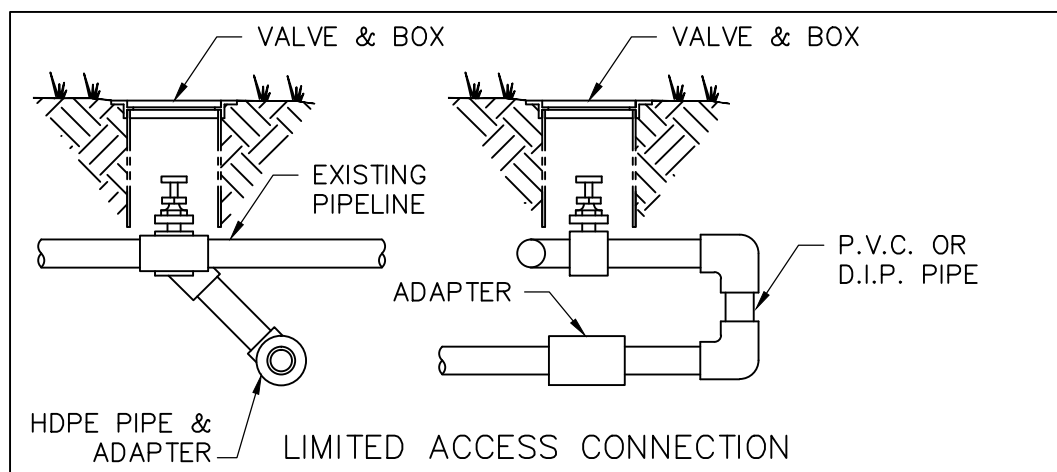
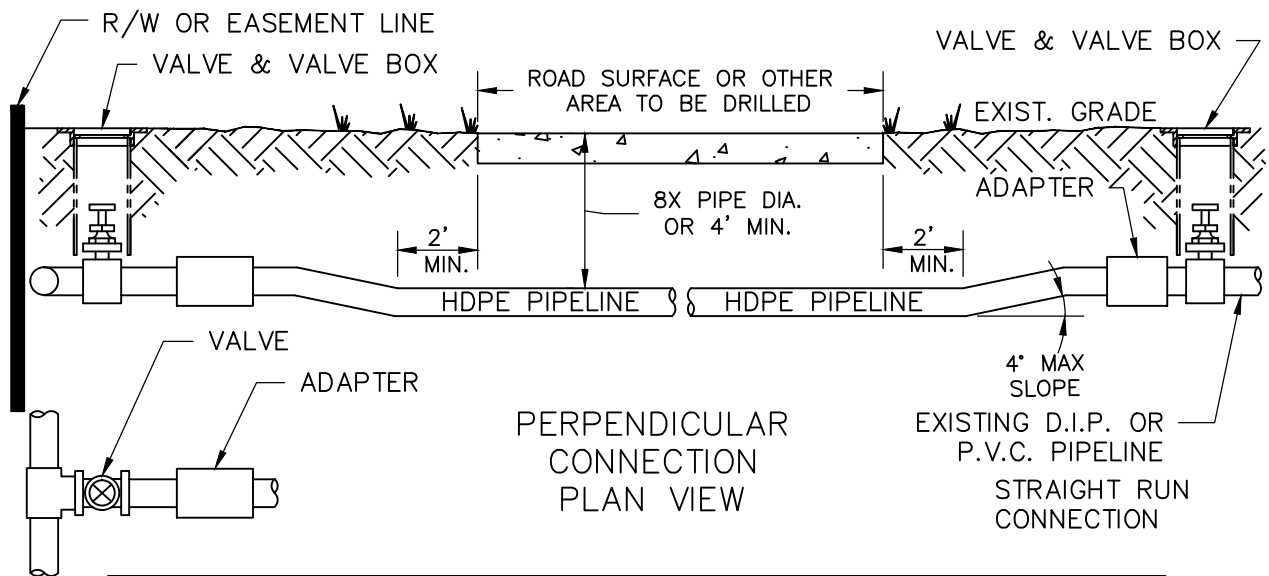

NOTES:

1. DIRECTIONAL DRILLS SHALL BE COMPLETED USING DR11 HDPE PIPE, DUCTILE IRON SIZE.
2. ALL DIRECTIONAL DRILLS SHALL BE AT A DEPTH OF 8X PIPE DIAMETER BELOW THE ROADWAY SURFACE OR 4' WHICHEVER IS GREATER.
3. ALL HDPE MUST BE COLOR CODED (SAFETY BLUE-WATER, SAFETY GREEN FOR SEWER AND PANTONE PURPLE FOR RECLAIMED WATER); BUTT FUSION WELDED; AND CONNECTED WITH HDPE-MJ ADAPTER.



BAY COUNTY  
UTILITIES  
STANDARD  
DETAILS

DIRECTIONAL BORE  
DETAIL

DATE : SEP 2020  
SCALE : NTS

FIGURE : G-20